

Product Highlights

Efficient and environmentally friendly

- Small turning radius, flexible operation in narrow spaces
- Standard forklift slot, for efficient equipment transportation
- Folding guardrails for easy transport

Reduced maintenance costs

- Double-door design for easy maintenance
- Troubleshooting for quick fault diagnosis
- Highly quality parts and components

More reliable performance

- Battery voltage early warning to ensure battery life
- Bumper rail protection
- The pothole protection reporting and horizontal protection system give peace of mind during operation

Standard features		
■ Maintenance-free battery	■ Automatic braking system	■ Drive at full height
■ Proportional control	■ Emergency lowering system	■ Forklift pocket and lifting eyes
■ Bumper rail	■ Emergency stop at both platform and ground controls	■ Electrophoresic painting technology
■ 4x2 drive	■ Fault diagnosis system	■ Foldable guardrail
■ Non-marking tyres	■ Tilt protection	■ Overload sensing system
■ Integrated hand shield	■ Automatic pothole guard	
Optional features		
■ Overhead anti-collision device	■ Headlight	■ RCBO
■ AC power to platform		

Model		0408S/M(1530S/1532M)	
Dimensions		Metric	US
Max Working Height		6.6m	21'8"
A	Max Platform Height	4.6m	15'1"
B	Max Horizontal Extension	0.9m	3'
C	Length-Stowed	1.78m	5'10"
D	Width-Stowed	0.76m/0.81m	2'6"/2'8"
Height	Stowed(Rail Folded)	1.84m	6'
	E Stowed (Rail Unfolded)	2.1m	6'11"
	Stowed(Fixed Rail)	2.1m	6'11"
	Stowed(Fixed Rail)	1.98m	6'6"
F	Wheelbase	1.325m	4'4"
Ground Clearance		70mm	2.8"
Platform Dimensions(LxWxH)		1.64m×0.76m×1.1m(5'5"×2'6"×3'7")	

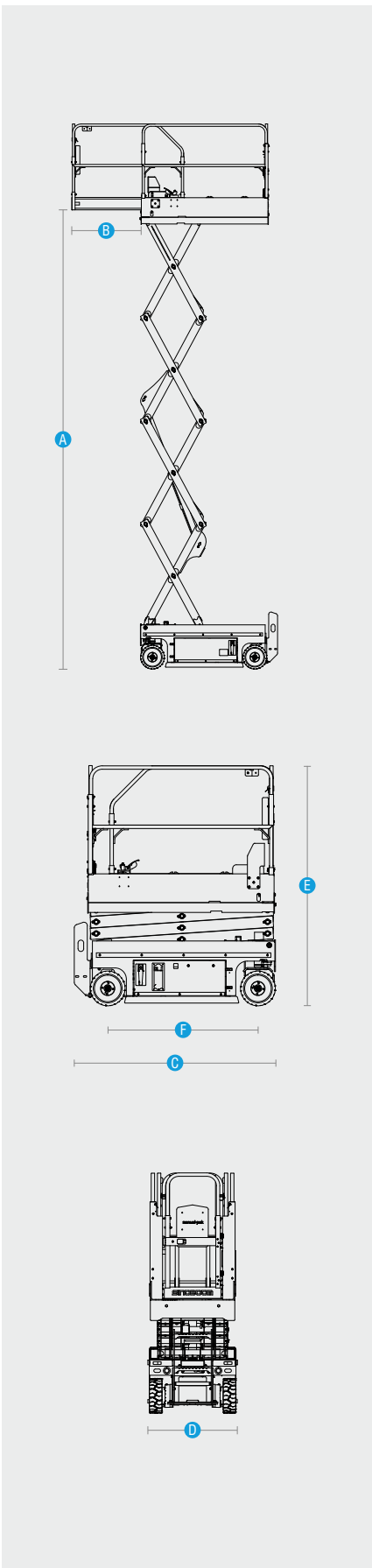

Performance	
Platform Allowable Occupants (Indoor/Outdoor)	0408S(1530S): 2 persons/- 0408M(1532M): 2 persons/1 person
Platform Capacity	280kg 617lbs
Drive Speed-Stowed	3km/h 1.86mph
Drive Speed-Raised	0.8km/h 0.5mph
Elevation Time(Unloaded)	15s~20s
Descent Time(Unloaded)	28s~33s
Gradeability	30%
Turning Radius(Inside/Outside)	0/1.49m 0' / 4'11"
Tilt Rating(Front to Back/Side to Side)	3°/1.5°
Tyres-solid	305×115mm 12"×4.5"

Power	
Batteries	6V×4/225Ah
Power Source	24V DC
Drive Mode	2WD, front wheel
Charger Input	100~240V AC
Charger Output	25A
Brake	2 rear wheel
Hydraulic System Capacity	14L 3gal

Weight	
Weight	1,330kg 2,932lbs
0408S(1530S) for indoor only	

Standards Compliance	ISO/CE/ANSI/CSA/AS/CU-TR/KCS
----------------------	------------------------------